

# DURAVALVE MODEL SM 310 NAMUR SOLENOID VALVE



## VALVE FEATURES AND BENEFITS

- **Large Internal Flow Area** - Enables usage on a large range of actuators
- **Balanced Spool** - Allows constant shifting force for pressure range (21 - 115 PSI)
- **1/4" NPT Ports** - For unrestricted flow
- **Aluminum Anodized Parts** - For corrosion protection
- **Air Assisted Spring Return** - To increase spring force
- **Epoxy Molded Coils** - Moisture proof and sealed from other elements
- **Manual Override Button** - Allows manual operation during setup and testing

## STANDARD FEATURES

- 3-Way for Spring Return
- 4-Way for Double Acting
- Weatherproof-NEMA 4
- NAMUR Mount
- DIN Connector

## OPTIONAL CONFIGURATION

- AC or DC voltage ratings
- Epoxy molded coil can be rotated 90° for 4 different positions
- Electrical casing can be rotated 180° for 2 different positions
- Conduit connector

## OPTIONAL ACCESSORIES

- Muffler for ports EA and EB for noise reduction
- Electric cable and end plug

## SPECIFICATIONS

Flow Media	Air (Filtered 40 Micron)	Voltage Deviation	±10%
Movement	Internal Guiding Piston	Power Consumption	AC (4.5 VA); DC (3W)
Port & Position	3-Way (3/2), 4-Way (5/2)	Anti-Static Rating	Class F
Port Dimension	1/4" NPT for Inlet & Exhaust	Protection Class	Class IP65 (DIN40050)
Lubrication	Not Necessary	Certification	CE
Operating Pressure	21 -115 PSI	Maximum Frequency	5 Per Second
Maximum Pressure	150 PSI	Minimum Discharge Time	0.05 Second
Operating Temperature	32 - 122° F	Duty Cycle	100%
CV	1.68	Weight	.67 lb.

## DIMENSIONS (4-WAY VALVE ILLUSTRATED)

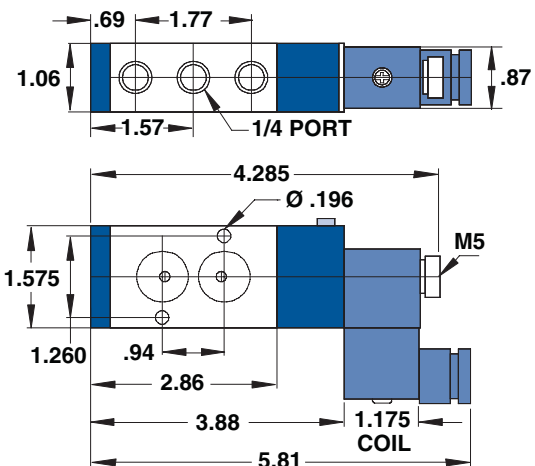

Figure 1

Available Coil Ratings	Part Number	
	3-Way	4-Way
AC 110 V 50/60 HZ 50mA	S105-3D	S310-D
AC 220 V 50/60 HZ 25mA	S220-3D	S220-4D
AC 24 V 50/60 HZ 240mA	S24A-3D	S24A-4D
DC 12 V 400mA	S109-3D	S109-4D
DC 24 V 200mA	S108-3D	S108-4D



# DURAVALVE MODEL SM 310 NAMUR SOLENOID VALVE

(4-WAY VALVE ILLUSTRATED)

## SEQUENCE OF OPERATION

When Solenoid Valve is Energized (Figure 2)

1. Spring loaded spool diaphragm moves left compressing the spring.
2. Inlet air from the compressor is allowed to flow from inlet port "P" and out through port "1" to the actuator.
3. Exhaust air from the actuator is allowed to flow into port "2" and out of the solenoid valve through exhaust port "EB".

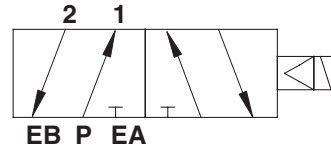

Figure 2: Simplified Operational Diagram

When Solenoid Valve is De-energized (Figure 3)

1. Loaded Spring is released moving the spool diaphragm to the right.
2. Inlet air from the compressor is allowed to flow from inlet port "P" out through port "2" to the actuator.
3. Exhaust air from the actuator is allowed to flow into port "1" and out of solenoid valve through exhaust port "EA".
4. **For Spring Return Actuator (Figure 4):** In the event of air failure to the inlet port "P", the loaded springs in the actuator are released. Exhaust air flows out of the actuator to port "2" and out of the solenoid valve through port "P". Atmosphere air flows from port "EA" to port "1" then into the actuator spring chamber.

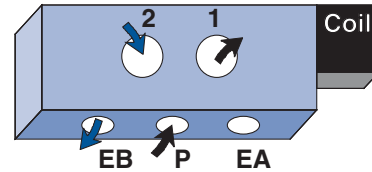

Figure 2: Air Flow Pattern (Solenoid Energized)

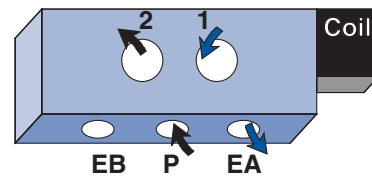

Figure 3: Air Flow Pattern (Solenoid De-energized)

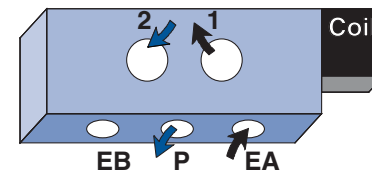

Figure 4: Air Flow Pattern (Air Failure to Port 1)

## INSTALLING THE ELECTRICAL CABLE

Before the solenoid valve can be put into service, electrical cable with end plug must be connected to the electrical casing.

1. Remove the electrical casing from the rest of the valve. This is easily done by loosening the 3.3mm screw (see Figure 5). Completely remove the 3.3mm screw from the casing.
2. After the casing is detached, a set of 3 narrow slots are revealed on the casing insert. Slots are identified by "1" for positive, "2" for negative and "⊖" for ground. The metal base for attaching copper wire is on the other side of the insert.
3. Pop out the casing insert with a small screw driver. The metal base is revealed.
4. Attach copper wires accordingly.
5. Replace the casing insert and attach the electrical casing back to the rest of valve body.

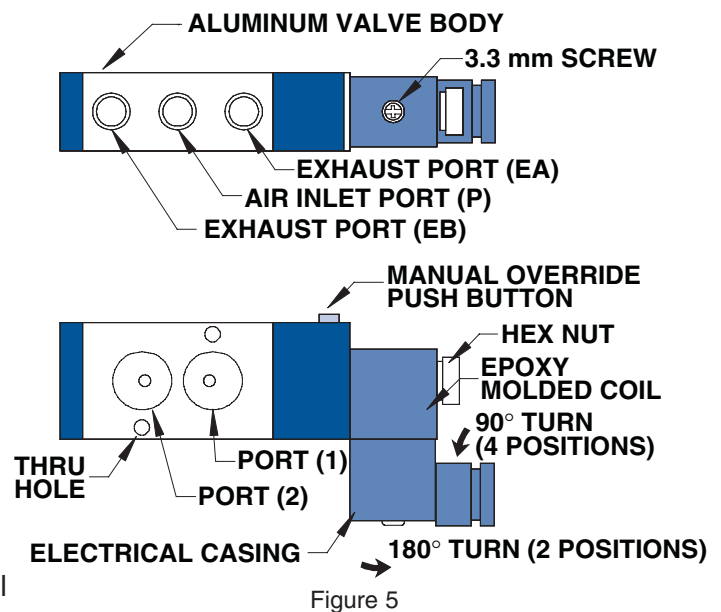

Figure 5

Note: The right is reserved to change or modify product design or construction without prior notice and without incurring any obligation to make such changes or modifications on products previously or subsequently sold.