

INSTALLATION OPERATION AND MAINTENANCE INSTRUCTIONS

DuraValve Electric Actuators

Thank you for selecting the DuraValve Actuator for your valve automation requirement. We here at DuraValve are proud of our products and feel confident they will meet or exceed your expectations of quality and reliability.

Every precaution has been taken to insure that your equipment will arrive undamaged; however, accidents do occur. Therefore, the first thing you must do upon receipt of your package is to inspect it for damage. If the box is damaged there is a possibility that the equipment inside the box may be damaged as well. If this is the case YOU MUST FILE A CLAIM with the delivering CARRIER. All shipments are F.O.B. Elk Grove, IL and it is YOUR RESPONSIBILITY to file a claim for damages.

STORAGE

If the actuators are scheduled for installation at a later date:

1. Store off the floor.
2. Store in a climate controlled building.
3. Store in a clean and dry area.

TOOLS REQUIRED

Models DR-2A, DR-2B

Cover screws 9/64" Allen wrench
Terminal strip screws 1/8" wide flat head screw driver
Cam setscrew 5/64" Allen wrench
Mounting pad screws 3/8" socket

Models DSR-5, DSX-5

Cover screws DS –Phillips head screwdriver
Deep Base –9/64 Allen wrench
NEMA 7 enclosure, 7/16" socket
Position indicator 5/64" Allen wrench
Terminal strip screws 1/8" wide flat head screw driver
Cam setscrew 5/64" Allen wrench
Mounting pad screws 3/8" socket.

Models DSH-10, DMR-15, DML-15, DMH-30

Cover screws: 5/32" Allen wrench,
NEMA 7 enclosure, 7/16" socket
Terminal strip screws 3/16" wide flat head screw driver
Cam setscrew 5/64" Allen wrench.
Mounting pad screws 1/2" socket.

Models DLA-12, DLX-14

Cover screws 7/16" socket.
Terminal strip screws 3/16" wide flat head screw driver.
Cam setscrew 5/64" Allen wrench.
Mounting pad screws 9/16" socket.

Model D5K-68

Cover screws 1/2" socket.
Terminal strip screws 3/16" wide flat head screw driver.
Cam setscrew 5/64" Allen wrench.
Mounting pad screws 3/4" socket.

Additional tools will be required for the screws to mount the valve to the actuator.

SUGGESTED MAXIMUM TORQUE VALUES FOR FASTENERS in In-Lb

Screw Size	Low Carbon Steel	18-8 SS	316 SS	Aluminum
2-56	2.2	2.5	2.6	1.4
4-40	4.7	5.2	5.5	2.9
6-32	9	10	10	5
8-32	18	20	21	10
10-24	21	23	24	13
10-32	30	32	33	19
1/4-20	65	75	79	45
5/16-18	129	132	138	80
3/8-16	212	236	247	143
1/2-13	465	517	542	313
5/8-11	1000	1110	1160	715

INSTALLATION

The actuator is shipped in the open position from the factory. It is important to make sure the valve and actuator are in the same position before mounting the actuator on the valve.

1. Manually open valve.
2. Remove valve mechanical stops. **CAUTION: DO NOT REMOVE** any parts necessary for the proper operation of the valve, i.e., packing gland, gland nut, etc.
3. Check again that the valve and actuator are in the same position.
4. Install mounting hardware on valve, do not tighten bolts securely at this time, mount actuator to valve, once actuator screws have been started, securely tighten all nuts and bolts.
NOTE: Actuator conduit entry is normally positioned perpendicular to pipe line.
5. Remove actuator cover.



6. Wire actuator using the wiring diagram inside cover.
CAUTION: Be sure power is off at the main power box.
7. Turn on power to actuator. **CAUTION:** Use extreme caution, as there are live circuits that could cause electrical shock or death.
8. Operate the valve to the close position, check the alignment.
9. Operate the valve to the open position, check the alignment.
10. Replace cover and secure cover screws.

CALIBRATION:

After checking the alignment of the valve port, calibration may be required.

To set the open position:

1. Operate valve to the open position by applying power to terminal connections #1 and #2. The valve will rotate counter clockwise, CCW, viewing top of actuator. **NOTE:** When the actuator is in the open position the setscrew securing the cam to the shaft will be easily accessible.
 - A. If valve did not open completely:
 - a. Loosen 8-32 set screw in top cam.
 - b. Rotate cam clockwise (CW) until the switch makes contact. Listen carefully for a slight click. The valve will begin to rotate CCW. By making small incremental CW movements of the cam the valve can be positioned precisely in the desired position.
 - c. Securely tighten the setscrew.
 - B. If valve traveled too far.

- CAUTION:** Valves with mechanical stops may be damaged or cause damage to the actuator if allowed to travel too far.
- a. Apply power to terminal connections #1 and #3. The valve will begin to rotate CW. Allow it to travel to the mid position.
 - b. Follow directions in A of "To set open position".

To set close position:

1. Operate valve to the close position by applying power to terminal connections #1 and #3. The valve will rotate CW viewing the top of the actuator. **NOTE:** When the actuator is in the close position, the setscrew securing the close cam to the shaft will be easily accessible.
 - A. If valve did not close completely:
 - a. Loosen 8-32 set screw in bottom cam.
 - b. Rotate cam CCW until the switch makes contact. Listen for a slight click. The valve will begin to rotate CW. By making small CCW incremental movements of the cam the valve can be positioned precisely in the close position.
 - c. Securely tighten the setscrew.
 - B If the valve has traveled too far closed.

CAUTION: Valves with mechanical stops may be damaged or cause damage to the actuator if allowed to travel too far closed.

 - a. Apply power to terminal connection #1 and #2. The valve will begin to rotate CCW. Allow to rotate to the mid position.
 - b. Follow directions in A of "To set close position".

TYPICAL WIRING DIAGRAM

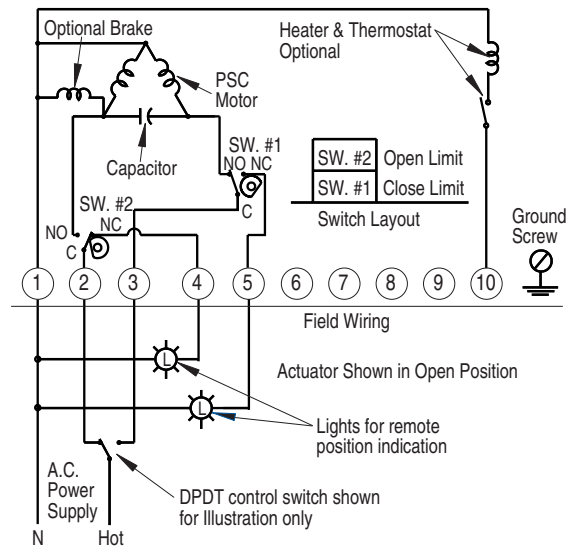

Notes:
Power to terminals 1 & 2 opens valve (CCW rotation).
Power to terminals 1 & 3 closes valve (CW rotation).
Terminals 4 & 5 for light indication.

TYPICAL WIRING DIAGRAM with TWO AUXILIARY SWITCHES

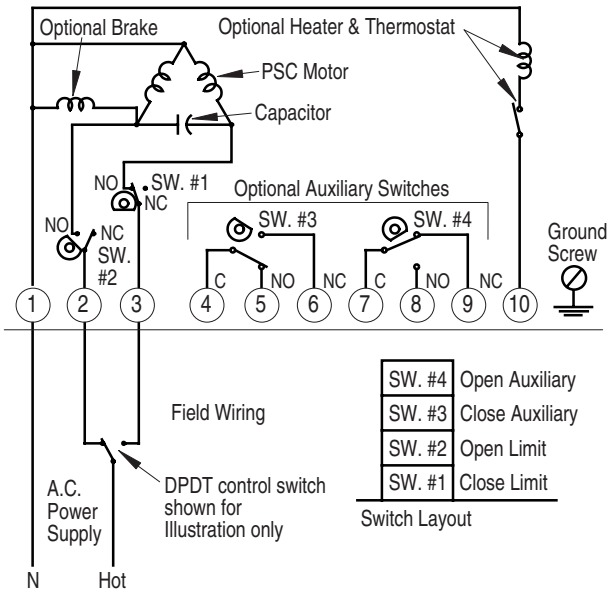

Notes:
Power to terminals 1 & 2 opens valve (CCW rotation).
Power to terminals 1 & 3 closes valve (CW rotation).
Terminals 4 through 9 for auxiliary switch connection.

Wiring diagram illustrates the actuator in the open position actuators are shipped in the open position unless otherwise specified.



MAINTENANCE:

After your DuraValve electric actuator has been properly installed there is little or no maintenance ever required. The gear train has been permanently lubricated at the factory and requires no routine maintenance. In the event it becomes necessary to perform maintenance on the actuator upon reassembling, we recommend using Shell Darina #2.

DUTY CYCLE:

DuraValve actuators rated 100 LB-IN up to 1500 LB-IN output torque are rated for 25% duty cycle at 100% ambient temperature at rated torque (75% duty cycle motors are available upon request). Actuators rated for 2000 LB-IN output torque and greater are rated for continuous duty. All direct current (dc) motors are rated for 75% duty cycle.

THERMAL OVER LOAD:

All alternating current (ac) motors are equipped with thermal over load protection to guard the motor against damage from over heating.

MECHANICAL OVER LOAD:

DuraValve actuators are all designed to withstand stall conditions. It is not recommended to subject the unit to repeated stall conditions; however, should it occur the actuator would not experience gear damage.

NEMA 7 ENCLOSURE:

In general, operation and maintenance of a NEMA 7 electric actuator is no different than that of a NEMA 4 electric actuator. However, there are some precautions that must be followed.

1. **DO NOT** install in ambient temperatures greater than 140 degrees F.
2. **DO NOT** under any circumstances remove the actuator cover while in a hazardous location. This could cause ignition of hazardous atmospheres.
3. **DO NOT** under any circumstances use a NEMA 7 electric actuator in a hazardous location that does not meet the specifications for which the actuator was designed. The actuator is clearly tagged with the NEMA classification it was designed for.
4. Mount, test and calibrate actuator on valve in non-hazardous location.
5. When removing the cover care must be taken not to scratch, scar or deform the flame path of the cover or base of the actuator. This will negate the NEMA 7 rating of the enclosure.
6. When replacing the cover on actuators rated NEMA 4 and 7 take care that the gasket is in place to assure the proper clearance after the cover is secured. After securing the cover screws check the clearance between the cover and the base, a .002" thick by 1/2" wide feeler gauge may not enter between the two mating faces more than .125".
7. All electrical connections must be to state and local codes and in accordance with the specifications for which the unit is being used.

After proper installation the actuator will require little or no maintenance. In the event maintenance is required remove it from the hazardous location before attempting to work on it. If the actuator is in a critical application and down time is not permitted it is advisable to have a spare actuator in stock.



TROUBLE SHOOTING:

SYMPTOM	PROBLEM	SOLUTION
Actuator does not respond to control signal.	Power not on.	Turn on power.
	Actuator wired wrong .	Check wiring diagram & rewire.
	Wrong voltage .	Check power supply & make appropriate changes.
	Thermal overload activated.	Allow motor to cool, actuator will automatically reset.
	Actuator and valve in opposite positions when actuator was mounted.	Remove actuator and rotate 90 degrees & remount.
Actuator will not open or close completely.	Travel limits set wrong.	Reset cams, see page 2.
	Valve torque too high for actuator.	Install correct size actuator.
	Mechanical stops not removed.	Remove stops, CAUTION: Do not remove any part required for proper operation.
Valve oscillates.	Valve torque too high for actuator.	Install correct size actuator.
	Actuator without brake installed on butterfly valve.	Install brake.
	Motor brake out of adjustment.	Adjust brake.
	Set screw loose in brake disc.	Adjust brake and tighten set screw.
Motor runs but output shaft does not rotate.	Gear damage or sheared pin.	Contact DuraValve or nearest distributor.

WARRANTY:

All DuraValve merchandise is guaranteed against defects in workmanship of material for a period of one year from date of invoice. In the event of such defects within the warranty period, DuraValve will, at its option, replace or recondition the product without charge. This shall constitute the exclusive remedy for breach of warranty, and DuraValve shall not be responsible for any incidental or consequential damages, including, without limitation, damages or other costs resulting from labor charges, delays, vandalism, negligence, fouling caused by foreign material, damage from adverse water conditions, chemicals, or any other circumstances over which DuraValve has no control. This warranty shall be invalidated by any abuse, misuse, misapplication or improper installation of the product.

DuraValve makes no other warranties expressed or implied.

SERVICE POLICY:

For inoperative products beyond the warranty period, DuraValve assumes no liability for replacement of product due to service wear or abuse.

