

INSTALLATION AND MAINTENANCE INSTRUCTIONS

for DuraValve 3-Pc. Stainless Steel Ball Valves Model D320A

1. GENERAL

The three- (3) piece DuraValve model D320A bidirectional ball valve has the “free-floating” ball principle. The ball is free to move with the line pressure in either direction and form a tight seal.

To facilitate in-line maintenance, all sizes of the model D320A valve are of the three-piece lift out type design. This assembly consists of a body and two end adapters. The body contains all parts subject to operational wear and can be replaced per instructions below.

2. INSTALLATION

The valve can be in any position employing standard pipe fitting procedures. (See paragraph six for the installation of the socket-weld end valves).

3. STEM PACKING ADJUSTMENT

In the event that leakage is noted in the stem packing area, tighten the gland nut (9) until it bottoms out and can no longer be tightened.

4. DISASSEMBLY-SEAT, SEAL AND PACKING REPLACEMENT WARNING

Prior to disassembly, insure that the line has been completely depressurized and that the valve is cycled two times to make sure that all pressure has been bled out from behind the ball.

A. With ball (3) in open position remove stem locknut (5) and washer (6) and lift off handle (7).

B. Remove top two body bolts, nuts and washers (14), (17) and (16). Loosen bottom two body bolts (14) by backing off nut (17) a minimum of two turns; body (center) section can now be lifted out.

Note: Prior to body section removal, the valve should be in the open position to insure correct removal.

C. The seats (8) and joint gasket (13) can be removed by turning the ball (3) to the closed position and pressing against the ball with your thumb, forcing it through the body cavity and pushing out the seat (8) and joint gasket (13). **Note: Extreme caution must be taken to avoid damage to the ball (3) (nicks, scratches, Etc.).** The other seat (8) and end cap (2) may be removed by pushing it out from the inside of the body.

Continued on page 2

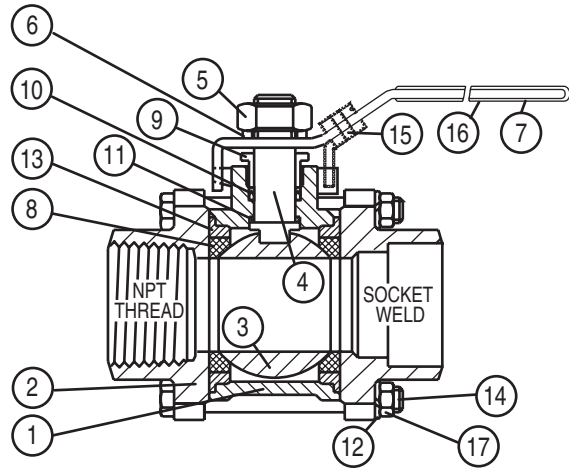

MATERIALS OF CONSTRUCTION

Item	Description	Material	Qty.
1.	Body	CF8M	1
2.	End Cap	CF8M	2
3.	Ball	316 SS	1
4.	Stem	316 SS	1
5.	Stem Nut	304 SS	1
6.	Stem Washer	304 SS	1
7.	Handle	304 SS	1
8.	Seat	RTFE	2
9.	Gland Nut	304 SS	1
10.	V-Ring Packing	PTFE	*
11.	Stem Seal	PTFE	1
12.	Bolt Washer	304 SS	**
13.	Joint Gasket	PTFE	2
14.	Bolt	304 SS	***
15.	Locking Device	304 SS	1
16.	Handle Sleeve	Vinyl	1
17.	Bolt Nut	304 SS	**

* 1/4" & 3/8" – regular one piece stem packing
 1/2" & 3" – one set of v-ring packing consists of 2 pcs.
 4" – one set of v-ring packing consists of 3 pcs.

** 1/4" to 2" – 4 pcs; 2-1/2" to 3" – 8 pcs; 4" – 12 pcs.

***1/4" to 3" – 4 bolts; 4" – 6 bolts



- D. Stem (4) to be removed from inside of the body (1). Unscrew and remove stem nut (5). A slight tap at the top of the stem will free the stem. The stem seal (11) should come out with stem. Examine ball (3) and stem (4) carefully for any nicks, scratches or pitting and replace if necessary.
- E. Remove all stem packings (10).
- F. **Extreme caution must be taken to prevent any damage to the sealing surfaces on face of end caps (2), and the polished face and counterbores in body (1).**

SEAL KITS

DuraValve recommends replacement of all soft parts whenever a valve has been disassembled. Seal kits for all sizes are available for purchase.

5. REASSEMBLY

Before reassembly, all metal sealing surfaces, ball, stem, thrust washer, stuffing box and body seal counterboxes should be thoroughly examined. A nick and scratch free surface is required for effective sealing.

- A. Place stem seal (11) onto stem (4) and insert stem into body (1) from the inside of the body bore.
- B. To install ball, the lower tang (flats) of stem (4) should be parallel to ball cavity. After ball is positioned, turn stem 90 degrees to the valve's open position. This will hold ball and prevent it from falling during installation of seats and end caps (3).
- C. Install seat (8) into body (1), making sure that spherical cavity of seat is positioned inward facing ball and the flanged lip of joint gasket is firmly secured into seal counterbore of body (1).
- D. Return body section back to the position in line between end adapters (2). Insert bolts (14) with lockwashers (12) and nuts (17) into position and finger tighten each nut.
- E. Rotate ball 90 degrees into closed position with handle flats on stem, perpendicular to valve.
- F. Evenly tighten all nuts going around 3 or 4 times in opposite corner sequence. Final torquing should effect metal to metal makeup of body (1) and end caps (2) and not exceed torque's shown below.

- G. Push square packing ring (10) over stem and into body stuffing box; follow with "V" type rings. Making sure that cup portions (lips) are facing downward and on top square ring, gently forcing rings downward into stuffing box. A short piece of tubing or pipe can be used to push rings into stuffing box.
- H. Thread gland nut (9) into stuffing box until gland nut is seated. Packing adjustment to be per paragraph 3 on preceding page.
- I. Install handle (7), stem washer (6), and stem nut (5).

6. SOCKET-WELD VALVE INSTRUCTION

Socket-Weld valves must be partially disassembled and center body section removed before welding to prevent heat damage or distortion of soft seats and seals. (See paragraph 4)

Note: Prior to removal of body section, end adapters should be tack-welded in line for bolt lineup and fit-up purposes. Reassembly of valve to be per reassembly instruction (paragraph 5).

- A. Base material of body end adapters should conform to cas stainless steel ASTM A315-CF8M.
- B. Prior to welding, push pipe into end adapter weld sockets and back off approximately 1/16"
- C. The socket and the welded section of the pipe must be free of any foreign material that may be detrimental to welding.
- D. Use the smallest electrode and minimum amperage, consistent with efficient welding. To minimize warping, tacks should be grounded out before completing the root pass in that area. Weld stringer beads with no weaving and stagger all starts and stops.

BOLT TORQUES

Valve Size (In.)	Torque (Ft.-Lbs.)
1/4 - 1	13
1 1/4	20
1 1/2 - 2	33
2 1/2	73
3 - 4	100

