

INSTALLATION AND MAINTENANCE INSTRUCTIONS

for DuraValve 3-Pc. Stainless Steel Ball Valves Model DM340

1. GENERAL

The three- (3) piece DuraValve Model DM340 bi-directional ball valve has the “free-floating” ball principle. The ball is free to move with the line pressure in either direction and form a tight seal.

To facilitate in-line maintenance, all sizes of the model DM340 valves are of the three-piece lift out type design. This assembly consists of a body and two end adapters. The body contains all parts subject to operational wear and can be replaced per instructions below.

2. INSTALLATION

The model DM340 valves can be in any position employing standard pipe fitting procedures. (See paragraph six for the installation of the socket-weld end valves.

3. STEM PACKING ADJUSTMENT

In the event that leakage is noted in the stem packing area, tighten the adjusting nut (14) until it bottoms out and can no longer be tightened.

4. DISASSEMBLY-SEAT, SEAL AND PACKING REPLACEMENT WARNING

Prior to disassembly, insure that the line has been completely depressurized and that the valve is cycled two times to make sure that all pressure has been bled out from behind the ball.

A. With ball (3) in open position. If valve is furnished with handle remove handle nut and washer and lift off handle. When valve has actuator mounted, remove 4 bolts holding actuator to valve and lift off actuator.

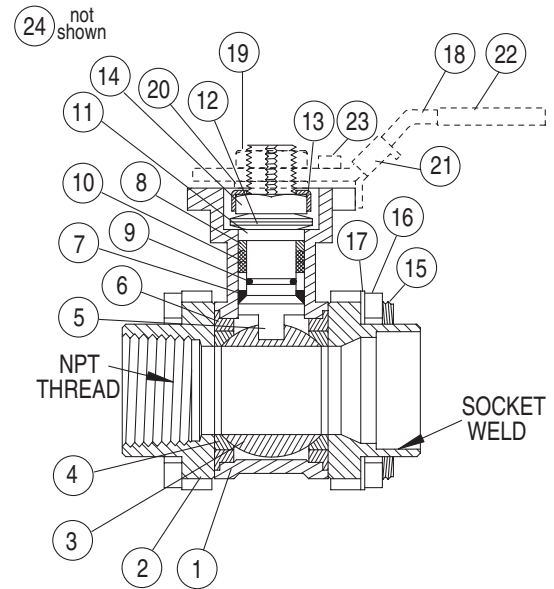

B. Remove lock saddle (13) adjusting nut (14) Two Belleville washers (12) and gland (11).

C. Remove top two bolts, nuts and washers (15), (16), (15). Loosen bottom two body bolts (17) by backing off nuts (16) a minimum of two turns. Body (center) can now be lifted out.

MATERIALS OF CONSTRUCTION

Item	Description	Material	Quantity	Item	Description	Material	Quantity
1.	Body	CF8M (316SS)	1	12.	Belleville Washer	301 SS	2
2.	End Adapters- Thd End Weld End	CF8M (316SS) CF3M (316L)	2	13.	Lock Saddle	304 SS	1
3.	Ball	316 SS	1	14.	Adjusting Nut	304 SS	1
4.	Seat	RTFE	2	15.	Bolt	304 SS	4
5.	Stem	316 SS	1	16.	Nut	304 SS	4
6.	End Seal	PTFE	2	17.	Washer	304 SS	4
7.	Thrust Washer	RTFE	1	18.	Handle*	304 SS	1
8.	Bushing	RTFE	1	19.	Handle Nut*	304 SS	1
9.	O-ring	Viton	1	20.	Stem Washer*	304 SS	1
10.	Packing	PTFE	2	21.	Locking Device*	304 SS	1
11.	Gland	304 SS	1	22.	Handle Sleeve*	Vinyl	1
				23.	Stop Pin*	304 SS	1
				24.	Anti-Static Device	304 SS	1

*Handle and associated components optional.

PACKING ADJUSTING NUT TORQUES	
VALVE SIZE	TORQUE-FT LBS
1/4" - 3/8"	7
1/2" - 3/4"	8
1" - 1-1/4"	9
1-1/2" - 2"	14
2-1/2", 3" & 4"	20

BOLT TORQUES	
VALVE SIZE	TORQUE-FT LBS
1/4" - 1"	13
1- 1/4"	20
1-1/2" - 2"	33
2-1/2"	73
3" - 4"	100



Note: Prior to body section removal, the valve should be in the open position to insure correct removal.

- D. The seats (4) and body seal (6) can be removed by turning the ball (4) to the closed position and pressing against the ball with your thumb, forcing it through the body cavity and pushing out the seat (4) and body seal. **Note: Extreme caution must be taken to avoid damage to the ball (3) (nicks, scratches, Etc.).** The other seat and body seal (2) may be removed by pushing it out from the inside of the body.
- E. Stem (5) to be removed from inside of the body (1). A slight tap at the top of the stem will free the stem. The thrust washer (7) should come out with stem. Examine ball (3) and stem (5) carefully for any nicks, scratches or pitting and replace if necessary.
- F. Remove all stem packings (10) and bushing (8).
- G. **Extreme caution must be taken to prevent any damage to the body seal (6), sealing surfaces on face of end adapters (3), and the polished face and counterbores in body (1).**

SEAL KITS

DuraValve recommends replacement of all soft parts whenever a valve has been disassembled. Seal kits for all sizes can be purchased from your local DuraValve Distributor.

5. REASSEMBLY

Before reassembly, all metal sealing surfaces, ball, stem, thrust washer, stuffing box and body seal counter bores should be thoroughly examined. A nick and scratch free surface is required for effective sealing.

- A. Place thrust washer (7) onto stem (5) with tapered I.D. of the thrust washer conforming to taper in stem. Place "O" Ring (9) on stem, making sure "O" Ring inserted into groove on stem did not get torn or damaged. Insert stem into body from inside body bore.
- B. To install ball, the lower tang (flats) of stem (5) should be parallel to ball cavity. After ball is positioned, turn stem 90 degrees to the valve's open position. This will hold ball and prevent it from falling during installation of seats and body seal (6)
- C. Install seat (6) into body (1), making sure that spherical cavity of seat is positioned inward facing ball and the flanged lip of body seal socket is firmly secured into seal counter bore of body (1).
- D. Return body section back to the position in line between end adapters (2). Insert bolts (15) with lockwashers (17) and nuts (16) into position and finger tighten each nut.
- E. Rotate ball 90 degrees into closed position with handle flats on stem, perpendicular to valve.

- F. Evenly tighten all nuts going around 3 or 4 times in opposite corner sequence. Final torquing should effect metal to metal makeup of body (1) and body ends (2) and not exceed torque's shown on page 1.
- G. Push square packing ring over stem and into body (10) stuffing box. Follow with "V" type ring and bushing (8). Making sure that cup portions (lips) are facing downward and on top square ring, gently forcing rings downward into stuffing box. A short piece of tubing or pipe can be used to push rings into stuffing box.
- H. Put metal gland (11) on top of bushing (8). Follow-up with two bellville washers (12) with concave (dished) portion opposite each other. Screw on adjusting nut (14) until it contacts top of bellville washer (12). Adjusting nut to be tightened to torque values shown on page 1.
- I. Install handle, lock-washer, and lock nut, if required for manual operation.

6. SOCKET-WELD VALVE INSTRUCTIONS

Socket-Weld valves must be partially disassembled and center body section removed before welding to prevent heat damage or distortion of soft seats and seals. (See paragraph 4)

Note: Prior to removal of body section, end adapters should be tack-welded in line for bolt lineup and fit-up purposes. Reassembly of valve to be per reassembly instruction (paragraph 5).

- A. Base material of body end adapters should conform to cast stainless steel ASTM A315-CF8M.
- B. Prior to welding, push pipe into end adapter weld sockets and back off approximately 1/16"
- C. The socket and the welded section of the pipe must be free of any foreign material that may be detrimental to welding.
- D. Use the smallest electrode and minimum amperage, consistent with efficient welding. To minimize warping, tacks should be grounded out before completing the root pass in that area. Weld stringer beads with no weaving and stagger all starts and stops.

